



EMC TEST REPORT

ETSI EN 301 489-1 V2.2.0 (2017-03)
ETSI EN 301 489-17 V3.2.0 (2017-03)

MEASUREMENT AND TEST REPORT

FOR

Guangzhou Baolun Electronics Co., Ltd.

No.1 Building, Zhongcun Industrial B Zone,Zhongcun Street, Panyu, Guangzhou, China

Model:TS-W100,TS-W100MS,TS-W100MD,TS-W101,TS-W101A,TS-W101S,TS-W101SA,TS-W102,TS-W102A,TS-W111,TS-W205,TS-W209,TS-W210,TS-W108,TS-W105,TS-W106,TS-W110,TS-0950M,TS-0590,TS-09591,TS-W115

January 25, 2019

This Report Concerns: Original Report	Equipment Type: Wireless digital conference system
Test Engineer:	Fan/ <i>Fan</i>
Report Number:	TH19AR-153T-3
Test Date:	January 18~25, 2019
Reviewed By:	Prince/ <i>[Signature]</i>
Approved By:	Prince/ <i>[Signature]</i>
Prepared By:	Shenzhen Tian Hai Test Technology Co.,Ltd. 4F, A3 BLDG, The Silicon Valley Power intelligent terminal industrial park, Guanlan street, Longhua district, Shenzhen Tel : +86-755-86615100 Fax: +86-755-86615105

Note: This test report is limited to the above client company and the product model only. It may not be duplicated without prior written consent of Shenzhen Tian Hai Test Technology Co.,Ltd.



1 - GENERAL ENERAL INFORMATION.....	4
1.1 PRODUCT DESCRIPTION FOR EQUIPMENT UNDER TEST (EUT).....	4
1.2 TEST STANDARDS.....	4
1.3 TEST METHODOLOGY.....	5
2 - SYSTEM TEST CONFIGURATION.....	6
2.1 JUSTIFICATION.....	6
2.2 EUT EXERCISE SOFTWARE.....	6
2.3 EQUIPMENT MODIFICATIONS.....	6
2.4 BASIC CONFIGURATION OF TEST SYSTEM.....	6
2.5 TEST SETUP DIAGRAM.....	6
3 - DISTURBANCE VOLTAGE AT THE MAINS TERMINALS.....	7
3.1 MEASUREMENT UNCERTAINTY.....	7
3.2 LIMIT OF DISTURBANCE VOLTAGE AT THE MAINS TERMINALS (CLASS B).....	7
3.3 EUT SETUP.....	7
3.4 INSTRUMENTS SETUP.....	8
3.5 TEST PROCEDURE.....	8
3.6 SUMMARY OF TEST RESULTS.....	8
3.7 DISTURBANCE VOLTAGE TEST DATA.....	8
3.8 TEST EQUIPMENT LIST AND DETAILS.....	8
3.9 TEST RESULT.....	8
4- RADIATED DISTURBANCES.....	11
4.1 MEASUREMENT UNCERTAINTY.....	11
4.2 LIMIT OF RADIATED DISTURBANCES (CLASS B).....	11
4.3 EUT SETUP.....	11
4.4 TEST RECEIVER SETUP.....	11
4.5 TEST PROCEDURE.....	12
4.6 CORRECTED AMPLITUDE & MARGIN CALCULATION.....	12
5 - ELECTROSTATIC DISCHARGE IMMUNITY TEST.....	13
5.1 BLOCK DIAGRAM OF TEST SETUP.....	13
5.2 TEST STANDARD.....	13
5.3 SEVERITY LEVELS AND PERFORMANCE CRITERION.....	13
5.4 OPERATING CONDITION OF EUT.....	13
5.5 TEST PROCEDURE.....	14
5.6 TEST EQUIPMENT LIST AND DETAILS.....	14
5.7 TEST RESULTS.....	14
6 - RF FIELD STRENGTH SUSCEPTIBILITY TEST.....	16
6.1 BLOCK DIAGRAM OF TEST.....	16
6.2 TEST STANDARD.....	16
6.3 SEVERITY LEVELS AND PERFORMANCE CRITERION.....	16
6.4 OPERATING CONDITION OF EUT.....	17
6.5 TEST PROCEDURE.....	17
6.6 TEST EQUIPMENT LIST AND DETAILS.....	17
6.7 TEST RESULTS.....	18
7 - ELECTRICAL FAST TRANSIENT/BURST IMMUNITY TEST.....	19
7.1 BLOCK DIAGRAM OF TEST SETUP.....	19
7.2 TEST STANDARD.....	19
7.3 SEVERITY LEVELS AND PERFORMANCE CRITERION.....	19
7.4 OPERATING CONDITION OF EUT.....	20
7.5 TEST PROCEDURE.....	20



7.6 TEST EQUIPMENT LIST AND DETAILS.....20

7.7 TEST RESULT.....20

8 - SURGE IMMUNITY TEST.....22

8.1 BLOCK DIAGRAM OF TEST SETUP.....22

8.2 TEST STANDARD.....22

8.3 SEVERITY LEVELS AND PERFORMANCE CRITERION.....22

8.4 OPERATING CONDITION OF EUT.....22

8.5 TEST PROCEDURE.....23

8.6 TEST RESULT.....23

9 - CONDUCTED SUSCEPTIBILITY TEST.....24

9.1 BLOCK DIAGRAM OF TEST SETUP.....24

9.2 TEST STANDARD.....24

9.3 SEVERITY LEVELS AND PERFORMANCE CRITERION.....24

9.4 OPERATING CONDITION OF EUT.....24

9.5 TEST PROCEDURE.....25

9.6 TEST RESULTS.....25

10 - VOLTAGE DIPS, SHORT INTERRUPTIONS IMMUNITY TESTS.....27

10.1 TEST SPECIFICATION.....27

10.2 TEST SETUP.....27

10.3 TEST PROCEDURE.....28

10.4 TEST EQUIPMENT LIST AND DETAILS.....28

10.5 PERFORMANCE CRITERION REQUIRED & TEST RESULT.....28

11 - TEST RESULTS.....29

11.1 EN 61000-4-2 ELECTROSTATIC DISCHARGE IMMUNITY TEST CONFIGURATION.....29

11.2 EN 61000-4-3 RADIATED SUSCEPTIBILITY TEST CONFIGURATION.....29

11.3 EN 61000-4-4 ELECTRICAL FAST TRANSIENT/BURST IMMUNITY TEST CONFIGURATION.....29

11.4 EN 61000-4-5 SURGE IMMUNITY TEST CONFIGURATION.....29

11.5 EN 61000-4-6 CONDUCTED SUSCEPTIBILITY TEST CONFIGURATION.....29

APPENDIX A - EUT PHOTOGRAPHS.....30

APPENDIX B - TEST SETUP PHOTOGRAPHS.....35



1 - GENERAL ENERAL INFORMATION

1.1 Product Description for Equipment Under Test (EUT)

Client Information

Applicant: **Guangzhou Baolun Electronics Co., Ltd.**

Address No.1 Building, Zhongcun Industrial B Zone,Zhongcun Street, Panyu, Guangzhou, China

Manufacturer: **Guangzhou Baolun Electronics Co., Ltd.**

Address No.1 Building, Zhongcun Industrial B Zone,Zhongcun Street, Panyu, Gangzhou, China

Factory: **Guangzhou Baolun Electronics Co., Ltd.**

Address No.1 Building, Zhongcun Industrial B Zone,Zhongcun Street, Panyu, Guangzhou, China

General Description of E.U.T

EUT Description: **Wireless digital conference system**

Model No.: TS-W100,TS-W100MS,TS-W100MD,TS-W101,TS-W101A,TS-W101S,TS-W101SA,TS-W102,TS-W102A,TS-W111,TS-W205,TS-W209,TS-W210,TS-W108,TS-W105,TS-W106,TS-W110,TS-0950M,TS-0590,TS-09591,TS-W115

Trade mark: 

Rating: Input: 100-240V~,50/60Hz,5A

Remark: * The test data gathered are from the production sample provided by the manufacturer.

1.2 Test Standards

The following Declaration of Conformity report of EUT is prepared in accordance with

ETSI EN 301 489-1 V2.2.0 (2017-03)

ETSI EN 301 489-17 V3.2.0 (2017-03)

The objective of the manufacturer is to demonstrate compliance with the described standards above.



1.3 Test Methodology

All measurements contained in this report were conducted with CISPR 16-1-1: 2006, radio disturbance and immunity measuring apparatus, and CISPR16-2-3: 2010, Method of measurement of disturbances and immunity.

All measurement required was performed at Shenzhen Hongcai Testing Technology Co.,Ltd.At 1st-3rd Floor,Building C,Shuanghuan Xin Yi Dai Hi-Tech Industrial Park,No.8 Baoqing Road,Baolong Industrial Zone,Longgang District, Shenzhen, Guangdong, China



2 - SYSTEM TEST CONFIGURATION

2.1 Justification

The system was configured for testing in a typical fashion (as normally used by a typical user).

2.2 EUT Exercise Software

The EUT exercising program used during radiated and conducted testing was designed to exercise the various system components in a manner similar to a typical use. The software offered by manufacture, can let the EUT being normal operation.

2.3 Equipment Modifications

The EUT tested was not modified by TH.

2.4 Basic Configuration of Test System

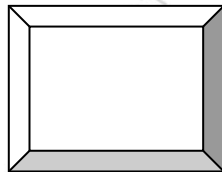

EUT

2.5 Test Setup Diagram

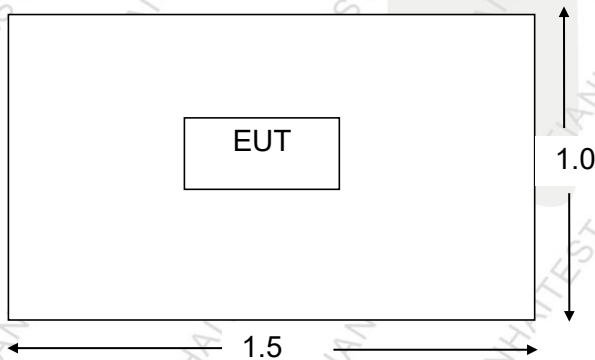



3 - DISTURBANCE VOLTAGE AT THE MAINS TERMINALS

3.1 Measurement Uncertainty

All measurements involve certain levels of uncertainties, especially in field of EMC. The factors contributing to uncertainties are spectrum analyzer, cable loss, and LISN.

The Treatment of Uncertainty in EMC Measurements, the best estimate of the uncertainty of any conducted emissions measurement is 3.4 dB.

3.2 Limit of Disturbance Voltage at The Mains Terminals (Class B)

Frequency Range (MHz)	Limits (dBuV)	
	Quasi-Peak	Average
0.150~0.500	66~56	59~46
0.500~5.000	56	46
5.000~30.00	60	50

Note: (1)The tighter limit shall apply at the edge between two frequency bands.

3.3 EUT Setup

The setup of EUT is according with CISPR 16-1, CISPR16-2 measurement procedure. See following test setup figure. The specification used was the EN 55014-1 limits.

The EUT was placed center and the back edge of the test table.

The AV cables were draped along the test table and bundled to 30-40cm in the middle.

The spacing between the peripherals was 10 cm.

Maximum emission emitted from EUT was determined by manipulating the EUT, support equipment, interconnecting cables and varying the mode of operation and the levels in the final result of the test were recorded with the EUT running in the operating mode that maximum emission was emitted.

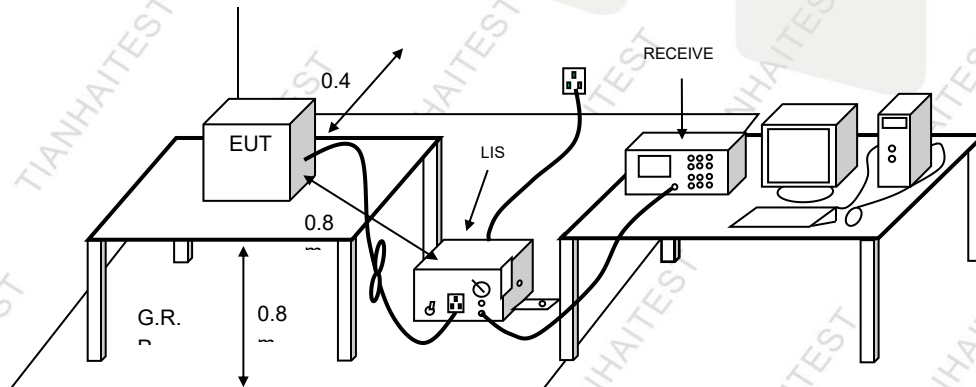



3.4 Instruments Setup

The test receiver was set with the following configurations:

Test Receiver Setting:

Frequency Range.....150 KHz to 30 MHz
 Detector.....Peak & Quasi-Peak & Average
 Sweep Speed.....Auto
 IF Band Width.....9 KHz

3.5 Test Procedure

During the conducted emission test, the EUT power cord was connected to the auxiliary outlet of the first Artificial Mains.

Maximizing procedure was performed on the six (6) highest emissions to ensure EUT compliance using all installation combination.

All data was recorded in the peak detection mode. Quasi-peak and Average readings were only performed when an emission was found to be marginal (within -10 dB_μV of specification limits). Quasi-peak readings are distinguished with a "QP". Average readings are distinguished with a "AV".

3.6 Summary of Test Results

According to the data in section 3.6, the EUT complied with the EN 55014-1 Conducted margin, which represented worst margin reading.

3.7 Disturbance Voltage Test Data

Temperature (°C)	15~35
Humidity (%RH)	30~60
Barometric Pressure (mbar)	860~1060
EUT	Wireless digital conference systemr
M/N	TS-W100
Operating Mode	On

Test data see following pages

3.8 Test Equipment List and Details

No.	Instrument no.	Equipment	Manufacturer	Model No.	S/N	Last Calculator	Due Calculator
1	BCT-EMC001	EMI Test Receiver	R&S	ESCI	100687	2018-03-16	2019-03-15
2	BCT-EMC020	Teo Line Single Phase Module	SCHWARZBECK	NSLK8128	8128247	2018-03-16	2019-03-15
3	BCT-EMC032	10dB attenuator	ELECTRO-METRICS	EM-7600	836	2018-03-16	2019-03-15

3.9 Test Result



PASS

Conducted Emission Test Data

EUT: Wireless digital conference systemr M/N: TS-W100
 Operating Condition: ON
 Test Site: Shielded Room
 Operator: Eric
 Test Specification: 220Vac
 Comment: Live Line Tem:26°C Hum:60%

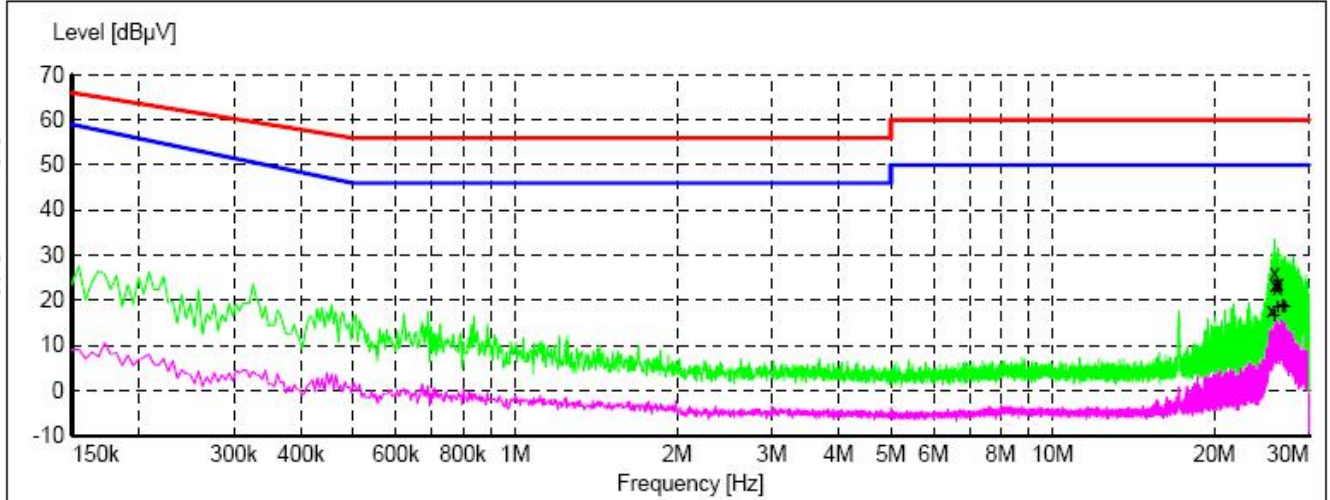

Frequency MHz	Level dBµV	Transd dB	Limit dBµV	Margin dB	Detector	Line	PE
25.562000	17.80	11.1	60	42.2	QP	L1	GND
25.868000	26.00	11.1	60	34.0	QP	L1	GND
25.934000	23.50	11.2	60	36.5	QP	L1	GND
26.174000	22.70	11.2	60	37.3	QP	L1	GND
26.234000	23.40	11.2	60	36.6	QP	L1	GND
26.294000	23.80	11.2	60	36.2	QP	L1	GND
Frequency MHz	Level dBµV	Transd dB	Limit dBµV	Margin dB	Detector	Line	PE
25.868000	16.60	11.1	50	33.4	AV	L1	GND
26.234000	18.40	11.2	50	31.6	AV	L1	GND
26.774000	18.40	11.2	50	31.6	AV	L1	GND
26.834000	19.10	11.2	50	30.9	AV	L1	GND
26.894000	18.40	11.2	50	31.6	AV	L1	GND
27.074000	18.50	11.2	50	31.5	AV	L1	GND



Conducted Emission Test Data

EUT: Wireless digital conference system M/N: TS-W100
 Operating Condition: ON
 Test Site: Shielded Room
 Operator: Eric
 Test Specification: 220Vac
 Comment: Neutral Line Tem:26°C Hum:60%

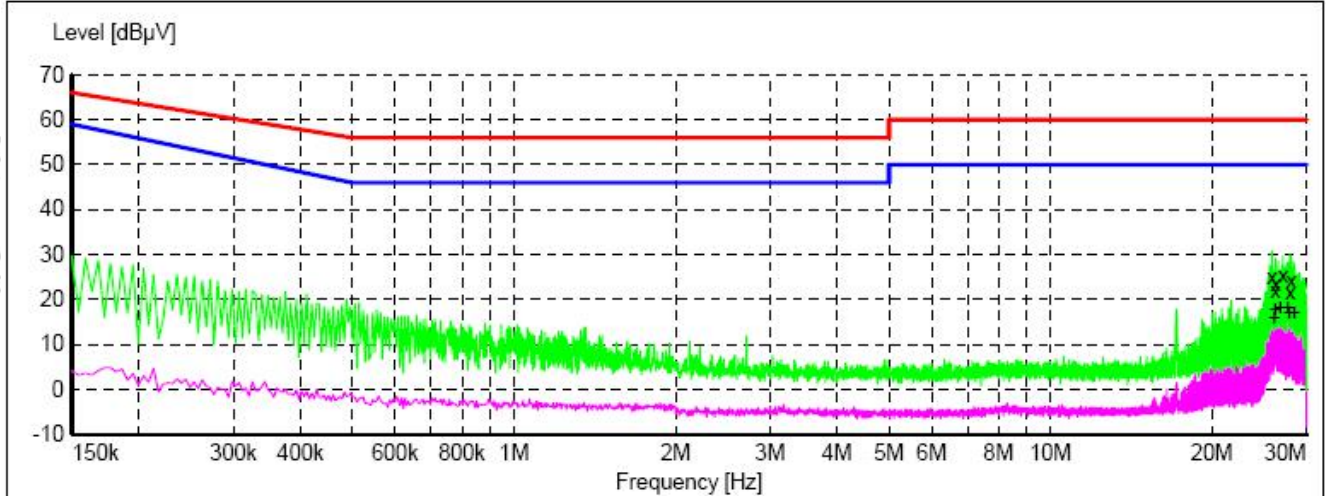

Frequency MHz	Level dBµV	Transd dB	Limit dBµV	Margin dB	Detector	Line	PE
25.868000	25.20	11.1	60	34.8	QP	N	GND
26.234000	22.00	11.2	60	38.0	QP	N	GND
26.294000	23.40	11.2	60	36.6	QP	N	GND
27.134000	25.30	11.2	60	34.7	QP	N	GND
27.974000	21.40	11.2	60	38.6	QP	N	GND
28.094000	24.10	11.2	60	35.9	QP	N	GND
Frequency MHz	Level dBµV	Transd dB	Limit dBµV	Margin dB	Detector	Line	PE
26.114000	15.90	11.2	50	34.1	AV	N	GND
26.174000	17.80	11.2	50	32.2	AV	N	GND
26.774000	18.20	11.2	50	31.8	AV	N	GND
27.674000	18.30	11.2	50	31.7	AV	N	GND
27.854000	17.00	11.2	50	33.0	AV	N	GND
28.460000	17.00	11.2	50	33.0	AV	N	GND



4- RADIATED DISTURBANCES

4.1 Measurement Uncertainty

All measurements involve certain levels of uncertainties, especially in field of EMC. The factors contributing to uncertainties are spectrum analyzer, cable loss, antenna factor calibration, antenna directivity, antenna factor variation with height, antenna phase center variation, antenna factor frequency interpolation, measurement distance variation, site imperfections, mismatch (average), and system repeatability.

The Treatment of Uncertainty in EMC Measurements, the best estimate of the uncertainty of a radiation emissions measurement is 4.0 dB.

4.2 Limit of Radiated Disturbances (Class B)

Frequency (MHz)	Distance (Meters)	Field Strengths Limits (dB μ V/m)
30 ~ 230	3	40
230 ~ 1000	3	47
1000 ~ 3000	3	70
3000 ~ 6000	3	74

Note: (1) The tighter limit shall apply at the edge between two frequency bands.
 (2) Distance refers to the distance in meters between the test instrument antenna and the closest point of any part of the E.U.T.

4.3 EUT Setup

The radiated emission tests were performed in the open area 3-meter test site, using the setup accordance with the CISPR 16-1, CISPR16-2. The specification used was EN 61000-6-3 Class B limits.

The EUT was placed on the center of the test table.

Maximum emission emitted from EUT was determined by manipulating the EUT, support equipment, interconnecting cables and varying the mode of operation and the levels in the final result of the test were recorded with the EUT running in the operating mode that maximum emission was emitted.

4.4 Test Receiver Setup

According to EN61000-6-3 rules, the frequency was investigated from 30 to 1000 MHz. During the radiated emission test, the test receiver was set with the following configurations:

Test Receiver Setting:

Detector.....Peak & Quasi-Peak
 IF Band Width.....120KHz
 Frequency Range.....30MHz to 1000MHz
 Turntable Rotated.....0 to 360 degrees

Antenna Position:

Height.....1m to 4m



Polarity.....Horizontal and Vertical

4.5 Test Procedure

Maximizing procedure was performed on the highest emissions to ensure that the EUT complied with all installation combinations.

All data was recorded in the peak detection mode. Quasi-peak readings performed only when an emission was found to be marginal (within -10 dBµV of specification limits), and are distinguished with a "QP" in the data table.

4.6 Corrected Amplitude & Margin Calculation

The Corrected Amplitude is calculated by adding the Antenna Factor and Cable Factor, and subtracting the Amplifier Gain from the Amplitude reading. The basic equation is as follows:

Corr. Ampl. = Indicated Reading + Antenna Factor + Cable Factor - Amplifier Gain

The "Margin" column of the following data tables indicates the degree of compliance with the applicable limit. For example, a margin of 7dBµV means the emission is 7dBµV below the maximum limit for Class A. The equation for margin calculation is as follows:

Margin = Class A Limit – Corr. Ampl.

4.7 Radiated Disturbances Test Result

Table with 2 columns: Parameter and Value. Rows include Temperature (15~35), Humidity (30~60), Barometric Pressure (860~1060), EUT (Wireless digital conference systemr), M/N (TS-W100), and Operating Mode (ON).

Test data see following pages

4.8 Test Equipment List and Details

Table with 8 columns: No., Instrument no., Equipment, Manufacturer, Model No., S/N, Last Calculator, Due Calculator. Contains 3 rows of equipment details.

Note: Due to EUT emission source below 108MHZ, there is no need for determination of 1GHz.

4.9 Test Result

PASS



5 - ELECTROSTATIC DISCHARGE IMMUNITY TEST

5.1 Block Diagram of Test Setup

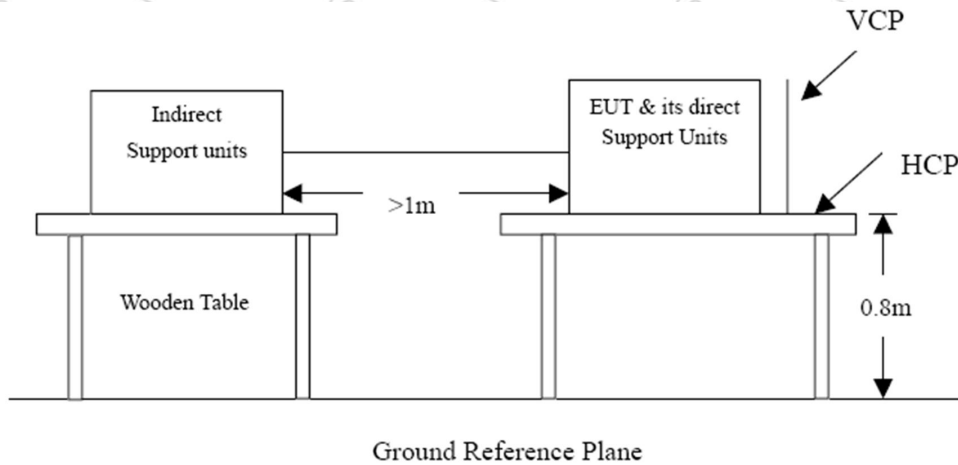

5.2 Test Standard

EN 61000-6-2:2005 (EN61000-4-2:2009 Severity Level: 3 / Air Discharge: $\pm 8\text{KV}$ Level: 2 / Contact Discharge: $\pm 4\text{KV}$)

5.3 Severity Levels and Performance Criterion

5.3.1 Severity level

Level	Test Voltage Contact Discharge (KV)	Test Voltage Air Discharge (KV)
1.	± 2	± 2
2.	± 4	± 4
3.	± 6	± 8
4.	± 8	± 15
X	Special	Special

5.3.2 Performance criterion: B

5.4 Operating Condition of EUT

5.4.1 Setup the EUT as shown on Section 5.1.

5.4.2 Turn on the power of all equipments.

5.4.3 Let the EUT work in measuring mode (Normal operation) and measure it.



5.5 Test Procedure

5.5.1 Air Discharge:

This test is done on a non-conductive surface. The round discharge tip of the discharge electrode shall be approached as fast as possible to touch the EUT. After each discharge, the discharge electrode shall be removed from the EUT. The generator is then re-triggered for a new single discharge and repeated 10 times for each pre-selected test point. This procedure shall be repeated until all the air discharge completed.

5.5.2 Contact Discharge:

All the procedure shall be same as Section 5.5.1. Except that the tip of the discharge electrode shall touch the EUT before the discharge switch is operated.

5.5.3 Indirect discharge for horizontal coupling plane

At least 10 single discharges (in the most sensitive polarity) shall be applied at the front edge of each HCP opposite the center point of each unit (if applicable) of the EUT and 0.1m from the front of the EUT. The long axis of the discharge electrode shall be in the plane of the HCP and perpendicular to its front edge during the discharge.

5.5.4 Indirect discharge for vertical coupling plane

At least 10 single discharge (in the most sensitive polarity) shall be applied to the center of one vertical edge of the coupling plane. The coupling plane, of dimensions 0.5m X 0.5m, is placed parallel to, and positioned at a distance of 0.1m from the EUT. Discharges shall be applied to the coupling plane, with this plane in sufficient different positions that the four faces of the EUT are completely illuminated.

5.6 Test Equipment List and Details

No.	Instrument no.	Equipment	Manufacturer	Model No.	S/N	Last Calculator	Due Calculator
1	BCT-EMC008	Electrostatic Discharge Simulator	TESEQ	NSG437	125	2018-03-20	2019-03-19

5.7 Test Results

PASS

Temperature (°C)	22~24
Humidity (%RH)	50~55
Barometric Pressure (mbar)	950~1000
EUT	Wireless digital conference systemr
M/N	TS-W100
Operating Mode	Normal operation



Please refer to the following pages

Table 1: Electrostatic Discharge Immunity (Air Discharge)

EN 61000-4-2 Test Points	Test Levels									
	-2 kV	+2 kV	-4 kV	+4 kV	-6 kV	+6 kV	-8 kV	+8 kV	-15 kV	+15 kV
Gap	A	A	A	A	A	A	A	A	/	/
Shell	A	A	A	A	A	A	A	A	/	/
Screw	A	A	A	A	A	A	A	A	/	/
Others	A	A	A	A	A	A	A	A	/	/

Table 2: Electrostatic Discharge Immunity (Direct Contact)

EN 61000-4-2 Test Points	Test Levels									
	-2 kV	+2 kV	-4 kV	+4 kV	-6 kV	+6 kV	-8 kV	+8 kV	-15 kV	+15 kV
Metal	A	A	A	A	/	/	/	/	/	/
Others	A	A	A	A	/	/	/	/	/	/

Table 3: Electrostatic Discharge Immunity (Indirect Contact HCP)

EN 61000-4-2 Test Points	Test Levels									
	-2 kV	+2 kV	-4 kV	+4 kV	-6 kV	+6 kV	-8 kV	+8 kV	-15 kV	+15 kV
Front Side	A	A	A	A	/	/	/	/	/	/
Back Side	A	A	A	A	/	/	/	/	/	/
Left Side	A	A	A	A	/	/	/	/	/	/
Right Side	A	A	A	A	/	/	/	/	/	/

Table 4: Electrostatic Discharge Immunity (Indirect Contact VCP)

EN 61000-4-2 Test Points	Test Levels									
	-2 kV	+2 kV	-4 kV	+4 kV	-6 kV	+6 kV	-8 kV	+8 kV	-15 kV	+15 kV
Front Side	A	A	A	A	/	/	/	/	/	/
Back Side	A	A	A	A	/	/	/	/	/	/
Left Side	A	A	A	A	/	/	/	/	/	/
Right Side	A	A	A	A	/	/	/	/	/	/



6 - RF FIELD STRENGTH SUSCEPTIBILITY TEST

6.1 Block Diagram of Test

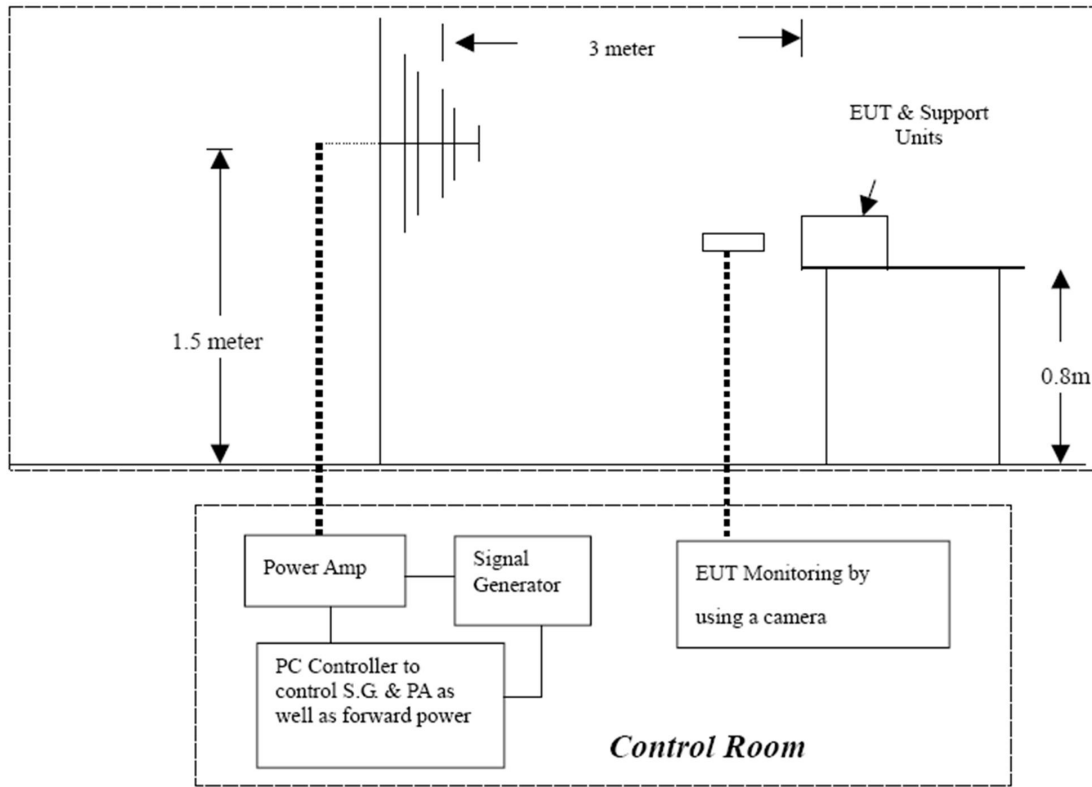

6.2 Test Standard

EN 61000-6-2:2005 (EN61000-4-3:2006+A2:2010, Severity Level: 1, 1V / m Level: 2, 3V / m, Level: 3, 10V / m)

6.3 Severity Levels and Performance Criterion

6.3.1 Severity Levels

Level	Field Strength V/m
1.	1
2.	3
3.	10
X	Special

6.3.2 Performance Criterion: A



6.4 Operating Condition of EUT

6.4.1 Setup the EUT as shown on Section 6.1.

6.4.2 Turn on the power of all equipments.

6.4.3 Let the EUT work in measuring mode (Normal operation) and measure it..

6.5 Test Procedure

The EUT are placed on a table which is 0.8 meter high above the ground. The EUT is set 3 meters away from the transmitting antenna which is mounted on an antenna tower. Both horizontal and vertical polarization of the antenna are set on test. Each of the four sides of the EUT must be faced this transmitting antenna and measured individually. In order to judge the EUT performance, a CCD camera is used to monitor its screen . All the scanning conditions are as following:

Condition of Test	Remark
1. Fielded Strength	10V/m, 3V/m, 1V/m
2. Radiated Signal	(Severity Level 3/ Level 2/ Level 1) Modulated
3. Scanning Frequency	80-1000MHz 1400-2700MHz
4. Sweep time of radiated	0.0015 Decade/s
5. Dwell Time	1 Sec.

6.6 Test Equipment List and Details

No.	Equipment	Manufacturer	Model No.	S/N	Calibration Date	Next Calibration Date
1	3M Chamber & Accessory Equipment	ETS-LINDGREN	FACT-3	3510	2018-03-16	2019-03-15
2	ESG Vector signal generators	Agilent	E4438C	MY45095744	2018-03-16	2019-03-15
3	Power Amplifier	AR	150W1000	0322288	2018-03-16	2019-03-15
4	Power Amplifier	AR	25S1G4A	0321112	2018-03-16	2019-03-15
5	TRILOG Broadband Antenna	schwarzbeck	VULB 9136	401	2018-03-16	2019-03-15
6	Horn Antenna	ETS-LINGREN	3117	00057407	2018-03-16	2019-03-15
7	3M Chamber & Accessory Equipment	ETS-LINDGREN	FACT-3	3510	2018-03-16	2019-03-15
8	Spectrum Analyzer	Agilent	E4440A	MY46185649	2018-03-16	2019-03-15
9	TRILOG Broadband Antenna	schwarzbeck	VULB 9136	401	2018-03-16	2019-03-15
10	Multi device Controller	ETS-LINGREN	2090	00057230	N/A	N/A
11	Horn Antenna	ETS-LINGREN	3117	00057407	2018-03-16	2019-03-15
12	Microwave Preamplifier	Agilent	8449B	3008A02425	2018-03-16	2019-03-15



6.7 Test Results

PASS

Please refer to the following page.

Temperature (°C)	22~24
Humidity (%RH)	50~55
Barometric Pressure (mbar)	950~1000
EUT	Wireless digital conference systemr
M/N	TS-W100
Operating Mode	Normal operation

Frequency Range (MHz)	Front (10 V/m)		Rear (10 V/m)		Left Side (10 V/m)		Right Side (10 V/m)	
	VERT	HORI	VERT	HORI	VERT	HORI	VERT	HORI
30-1000	A	A	A	A	A	A	A	A

Frequency Range (MHz)	Front (3 V/m)		Rear (3 V/m)		Left Side (3 V/m)		Right Side (3 V/m)	
	VERT	HORI	VERT	HORI	VERT	HORI	VERT	HORI
1000-3000	A	A	A	A	A	A	A	A

Frequency Range (MHz)	Front (1 V/m)		Rear (1 V/m)		Left Side (1 V/m)		Right Side (1 V/m)	
	VERT	HORI	VERT	HORI	VERT	HORI	VERT	HORI
3000-6000	A	A	A	A	A	A	A	A



7 - Electrical Fast Transient/Burst Immunity Test

7.1 Block Diagram of Test Setup

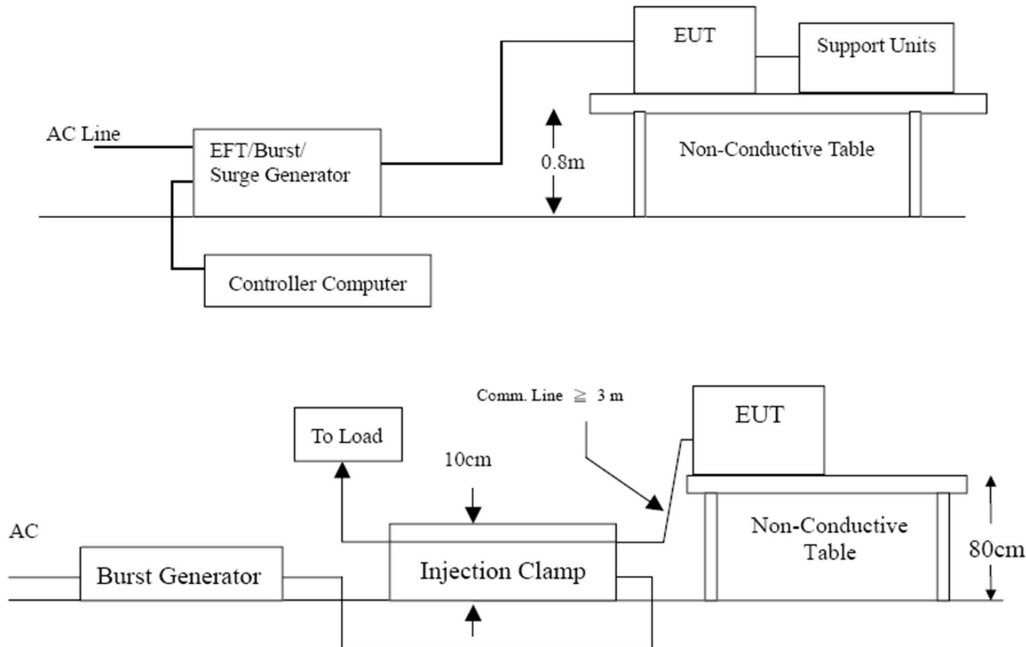

7.2 Test Standard

EN 61000-6-2:2005, (EN61000-4-4:2012, Severity Level, Level 3:2KV)

7.3 Severity Levels and Performance Criterion

7.3.1 Severity level

Open Circuit Output Test Voltage $\pm 10\%$		
Level	On Power Supply Lines	On I/O (Input/Output) Signal data and control lines
1.	0.5 KV	0.25 KV
2.	1 KV	0.5 KV
3.	2 KV	1 KV
4.	4 KV	2 KV
X	Special	Special

7.3.2 Performance criterion: B



7.4 Operating Condition of EUT

7.4.1 Setup the EUT as shown in Section 117.1.

7.4.2 Turn on the power of all equipments.

7.4.3 Let the EUT work in test mode (Full loadNormal Operation) and measure it.

7.5 Test Procedure

The EUT is put on the table which is 0.8 meter high above the ground. This reference ground plane shall project beyond the EUT by at least 0.1m on all sides and the minimum distance between EUT and all other conductive structure, except the ground plane beneath the EUT, shall be more than 0.5m.

7.5.1 For input and output AC power ports:

It's unnecessary to test

7.5.2 For signal lines and control lines ports:

It's unnecessary to test.

7.5.3 For DC Input line ports:

The EUT is connected to the DC power mains by using a coupling device which couples the EFT interference signal to DC power lines. Both polarities of the test voltage should be applied during compliance test and the duration of the test is 2 mins.

7.6 Test Equipment List and Details

No.	Instrument no.	Equipment	Manufacturer	Model No.	S/N	Calibration Date	Next Calibration Date
1	BCT-EMC009	Fast Transient Burst Generator	SCHAFFNER	MODULA6150	34572	2018-03-16	2019-03-15

7.7 Test Result

PASS

Report No.: TH19AR-153T-3

Page 20 of 35



Please refer to the following page:

Temperature (°C)	22~24
Humidity (%RH)	50~55
Barometric Pressure (mbar)	950~1000
EUT	Wireless digital conference systemr
M/N	TS-W100
Operating Mode	Normal operation

IEC 61000-4-4 Test Points		Test Levels (kV)							
		+0.5	-0.5	+1.0	-1.0	+2.0	-2.0	+4.0	-4.0
Power Supply	P	A	A	A	A	A	A	/	/
	N	A	A	A	A	A	A	/	/
	P+N	A	A	A	A	A	A	/	/
Power Line of EUT	P+PE	A	A	A	A	A	A	/	/
	N+PE	A	A	A	A	A	A	/	/
	P+N+PE	A	A	A	A	A	A	/	/

Note: P stands for positive line, N stands for negative line.



8 - Surge Immunity Test

8.1 Block Diagram of Test Setup

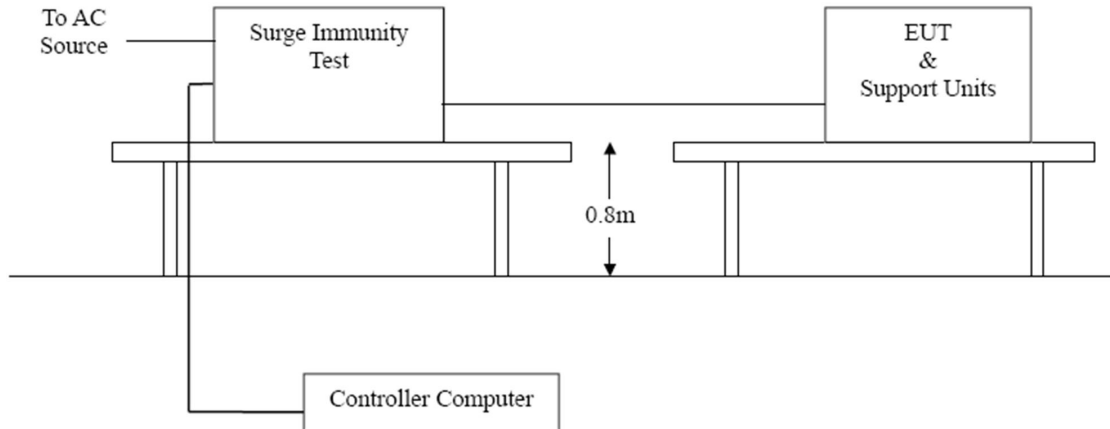

8.2 Test Standard

EN 61000-6-2:2005, (IEC 61000-4-5:2014 Severity Level: Line to Line, Level 2: 1KV, Line to Earth, Level 3: 2KV)

8.3 Severity Levels and Performance Criterion

8.3.1 Severity level

Severity Level	Open-Circuit Test Voltage KV
1	0.5
2	1.0
3	2.0
4	4.0
*	Special

8.3.2 Performance criterion : B

8.4 Operating Condition of EUT

8.4.1 Setup the EUT as shown in Section 28.1.

8.4.2. Turn on the power of all equipments.

8.4.3. Let the EUT work in test mode (Full load Normal operation) and measure it.



8.5 Test Procedure

- 1)Set up the EUT and test generator as shown on Section 8.1.
- 2)For AC port coupling mode, provide a 1 KV 1.2/50us voltage surge (at open-circuit condition) and 8/20us current surge to EUT selected points.
- 3)At least 5 positive and 5 negative (polarity) tests with a maximum 1/min repetition rate are conducted during test.
- 4)Record the EUT operating situation during compliance test and decide the EUT immunity criterion for above each test.

8.6 Test Result

PASS

Please refer to the following page.

Temperature (°C)	22~24
Humidity (%RH)	50~55
Barometric Pressure (mbar)	950~1000
EUT	Wireless digital conference systemr
M/N	TS-W100
Operating Mode	Normal operation

Table 1: Surge Power Supply (DC POWER SUPPLY Power Line of EUT)

Level	Voltage	Poll	Path	Pass	Fail
1	0.5kV	±	P-N	A	/
2	1kV	±	P-N	A	/
3	2kV	±	P-PE, N-PE	A	/
4	4kV	±	P-N, P-PE, N-PE	A	/

Note: P stands for positive line, N stands for negative line.



9 - Conducted Susceptibility Test

9.1 Block Diagram of Test Setup

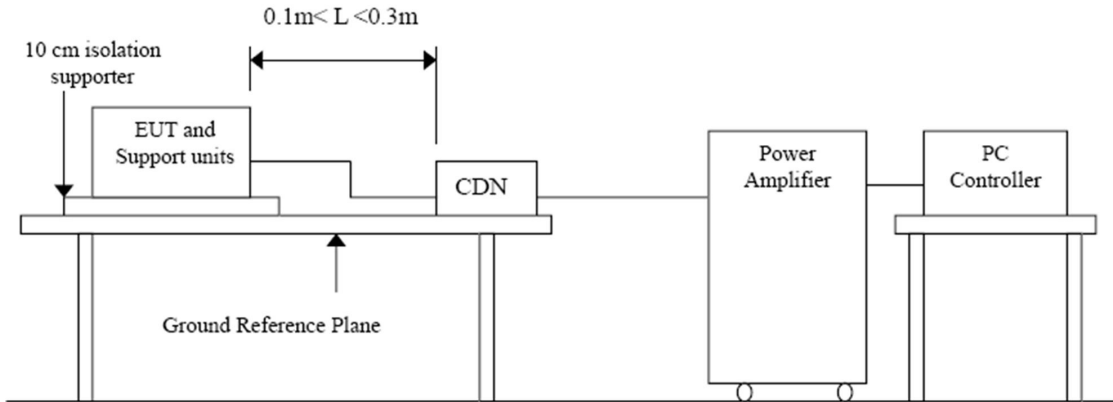

9.2 Test Standard

EN 61000-6-2:2005 (EN 61000-4-6:2014, Severity Level 3: 10V (rms)).(0.15MHz ~ 80MHz)

9.3 Severity Levels and Performance Criterion

9.3.1 Severity level

Level	Field Strength V(rms)
1.	1
2.	3
3.	10
X	Special

9.3.2 Performance criterion: A

9.4 Operating Condition of EUT

9.4.1 Setup the EUT as shown in Section 38.1.

9.4.2 Turn on the power of all equipments.

9.4.3 Let the EUT work in test mode (Full load/Normal operation) and measure it.



9.5 Test Procedure

9.5.1 For AC Input line ports:
It's unnecessary to test.

9.5.2 For signal lines and control lines ports:

It's unnecessary to test.

9.5.3 For DC Mains:

- 1) Set up the EUT, CDN and test generators as shown on Section 8.1.
- 2) Let the EUT work in test mode and measure it.
- 3) The EUT are placed on an insulating support 0.1m high above a ground reference plane. CDN (coupling and decoupling network) is placed on the ground plane about 0.3m from EUT. Cables between CDN and EUT are as short as possible, and their height above the ground reference plane shall be between 30 and 50 mm (where possible).
- 4) The disturbance signal described below is injected to EUT through CDN.
- 5) The EUT operates within its operational mode(s) under intended climatic conditions after power on.
- 6) The frequency range is swept from 150KHz to 80MHz using 3V signal level, and with the disturbance signal 80% amplitude modulated with a 1KHz sine wave.
- 7) The rate of sweep shall not exceed 1.5×10^{-3} decades/s. Where the frequency is swept incrementally, the step size shall not exceed 1% of the start and thereafter 1% of the preceding frequency value.

Recording the EUT operating situation during compliance testing and decide the EUT immunity criterion.

9.6 Test Results

PASS



Please refer to the following page.

Frequency Range (MHz): 0.15~80MHz
Modulation: Amplitude 80%, 1kHz sinewave
Severity Level: 10Vr.m.s.

Temperature (°C)	22~24
Humidity (%RH)	50~55
Barometric Pressure (mbar)	950~1000
EUT	Wireless digital conference systemr
M/N	TS-W100
Operating Mode	Normal operation

Level	Voltage Level (e.m.f.) U ₀	Pass	Fail
1	1	/	/
2	3	/	/
3	10	A	/
X	Special	/	/



10 - Voltage Dips, Short Interruptions Immunity Tests

10.1 Test Specification

Basic Standard:	IEC/EN 61000-4-11
Test Level:	Voltage Dips: 1) 0% residual voltage for 0.5 cycle, 2) 70% residual voltage for 25 cycles, Voltage Interruptions: 0% residual voltage for 250 cycles
Interval between event:	10 seconds
Phase Angle:	0°/180°
Test cycle:	3 times
Temperature:	22~23 (°C)
Humidity:	50~54 (%RH)
Barometric Pressure:	950~1000 (mbar)
Operating Mode:	Normal Operation

10.2 Test Setup

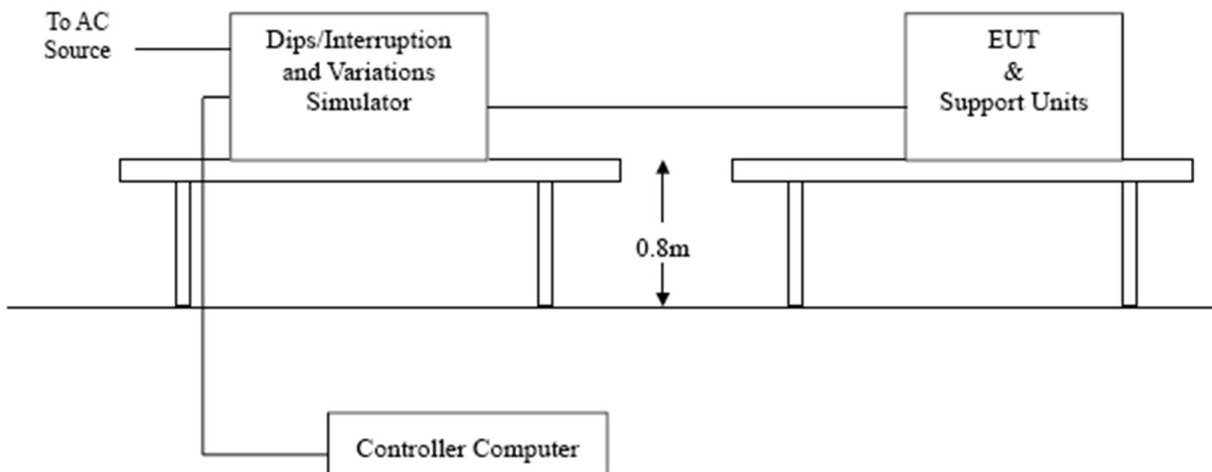



10.3 Test Procedure

The EUT was tested for each selected combination of test levels and duration with a sequence of 3 dips/interruptions with intervals of 10s (between each test event). Each representative mode of operation shall be tested. Abrupt changes in supply voltage shall occur at zero crossings of the voltage waveform.

10.4 Test Equipment List and Details

No.	Instrument no.	Equipment	Manufacturer	Model No.	S/N	Last Calculator	Due Calculator
1	BCT-EMC009	Fast Transient Burst Generator	SCHAFFNER	MODULA6150	34572	2018-03-16	2019-03-15

10.5 Performance Criterion Required & Test Result

Voltage (% Residual)	Duration (Period)	Observation Performance	Criterion Required
0	0.5	A	B
70	25	B	C
0	250	C	C

Test Result: Pass



11 - TEST RESULTS

The following tests were performed on the EUT; the actual test results are contained within the Test Data section of this report.

11.1 EN 61000-4-2 Electrostatic Discharge Immunity Test Configuration

The EUT was subjected to the electrostatic discharge tests required by EN 61000-6-1 and all lower levels specified in EN 61000-4-2.

The EUT continued to perform as intended during and after the application of the ESD. Test setup photographs presented in Appendix B.

11.2 EN 61000-4-3 Radiated Susceptibility Test Configuration

The EUT was subjected to a 3-volt/meter, 80% Amplitude, 1 kHz Sine wave field as required by EN 61000-6-1 and all lower levels specified in EN 61000-4-3.

The EUT continued to perform as intended during and after the application of the electromagnetic field. Test setup photographs presented in Appendix B.

11.3 EN 61000-4-4 Electrical Fast Transient/Burst Immunity Test Configuration

The EUT was subjected to the electrical fast transient tests required by EN EN 61000-6-2 and all lower levels specified in EN61000-4-4.

The EUT continued to perform as intended during and after the application of the EFT/B. Test setup photographs presented in Appendix B.

11.4 EN 61000-4-5 Surge Immunity Test Configuration

The EUT was subjected to the Surge Immunity tests required by EN 61000-6-2 and all lower levels specified in EN 61000-4-5.

The EUT continued to perform as intended during and after the application of the Surge Immunity Test. Test setup photographs presented in Appendix B.

11.5 EN 61000-4-6 Conducted Susceptibility Test Configuration

The EUT was subjected to the Conducted Susceptibility tests required by EN 61000-6-2 and all lower levels specified in EN 61000-4-6.

The EUT continued to perform as intended during and after the application of the Conducted Susceptibility Test. Test setup photographs presented in Appendix B.



APPENDIX A - EUT PHOTOGRAPHS



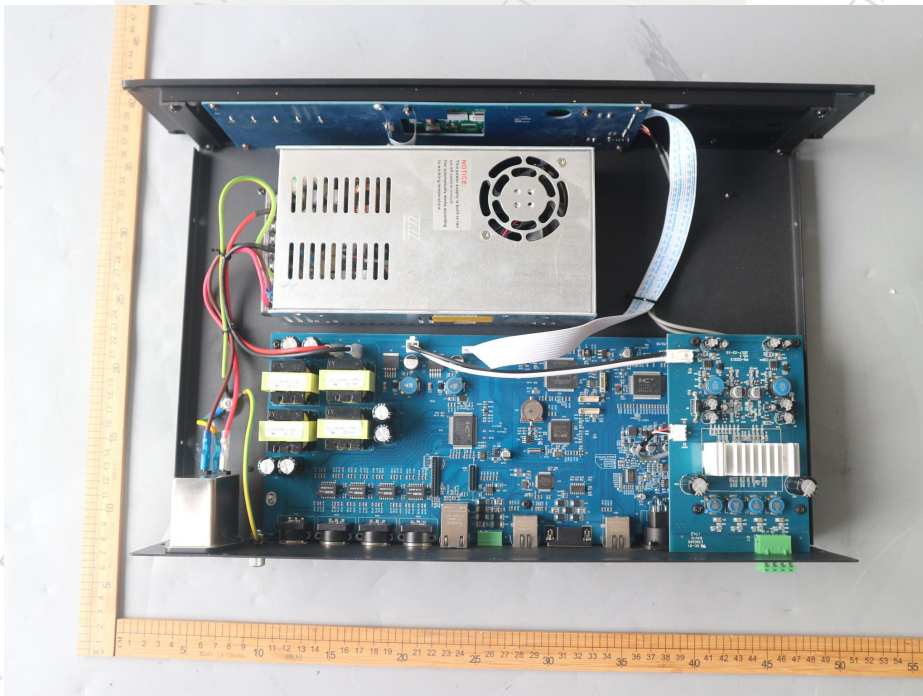



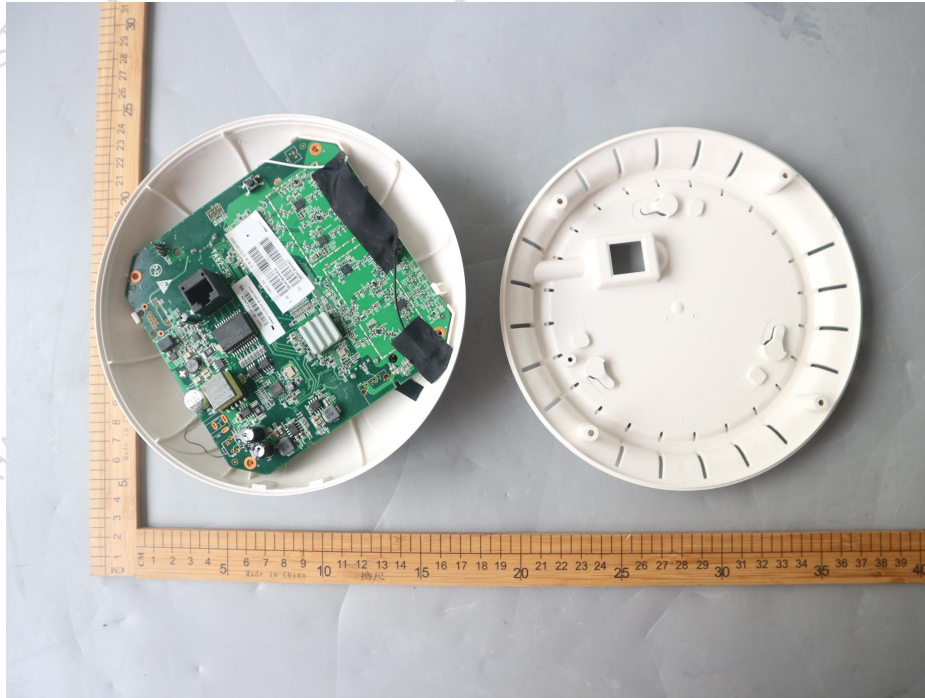





APPENDIX B - TEST SETUP PHOTOGRAPHS



*****END OF THE REPORT*****